

ringg®

CE Sedex®



The Flame
Is Yours

f @ ▶ in
ringgoutdoor

Stocked in Chicago. Delivered Across the U.S.

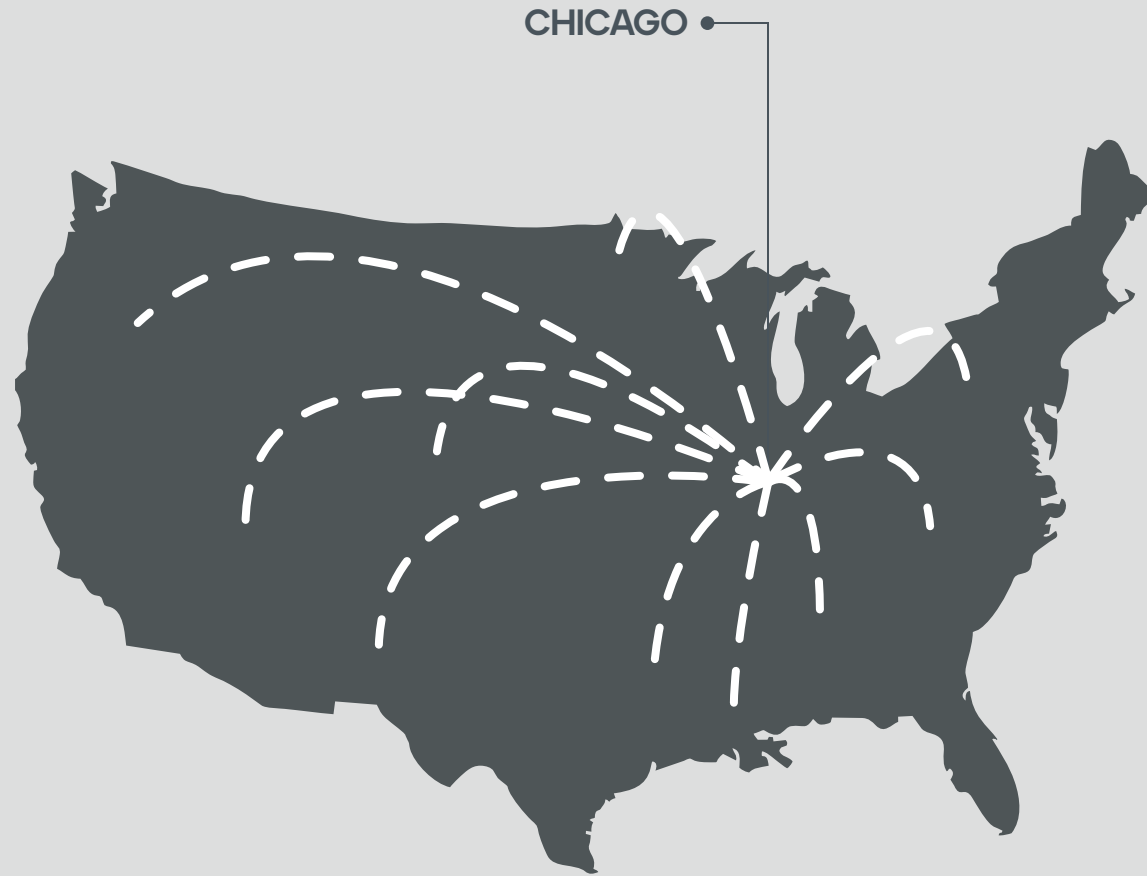

500 units of inventory
available of each SKU

Why Partner With Ringg Outdoor?



High margin
products



Growing outdoor
cooking trend



Easy
logistics



US & EU
presence



Scalable
product range

Technical Advantages



Even Heat
Distribution



Heat
Control



High
BTU



Easy Setup
and Storage



No Tools
Required



Easy
to Clean



More Cooking
Space



Consistent
Results



Fuel
Efficiency

The multi-ring burner system ensures even heat distribution across the entire cooking surface, supporting consistent cooking results.

Based on internal testing, Ringg delivers more stable and reliable heat performance compared to similar products, making it easier to achieve consistent results every time.

Our References

amazon

Walmart 

TARGET



 **TRACTOR
SUPPLY CO**

 **BAUHAUS**

makro

METRO

Let's Gather Around the Flame with Ringg Outdoor

Fire is one of the oldest gathering points in human history. Ringg Outdoor brings this tradition into the modern world, offering a modern and eco-friendly experience that brings people together.

Gathering around a fire is a symbol of sharing and togetherness. Ringg Outdoor keeps this tradition alive.

Ringg Outdoor is not just a cooking tool - it is a shared experience.



Why Ringg Outdoor?

Design That Controls Flame Distribution



Perfect cooking results thanks to even heat distribution.



Cook with ease thanks to the large cooking surface.







A clean and comfortable experience with smoke and flame control.







Technical Advantages

Comparison with Coal-Fired Products

	Feature	Ringg Outdoor Gas Burners	Charcoal Grills
	Heat Distribution	Even and Controlled	Irregular
	Fuel Efficiency	High	Low
	Ease of Cleaning	Practical	Difficult
	Environmental Impact	Low Emission	High Emission

Comparison with Industrial Products

	Feature	Ringg Outdoor Gas Burners	Industrial-Grade Barbecues
	Heat Distribution	Homogeneous - ensures even heat distribution throughout the entire dish	Unevenly cooked - some parts are overcooked, others undercooked
	Pressure Level	Low pressure - safe and controlled	High pressure - noise and uncontrolled
	Tube Compatibility	It runs on a household propane gas tank	A large-diameter pipe is required for this specific connection
	User Profile	Amateur and professional users	The special connection requires a large tube
	Portability	Lightweight, foldable, and easy to carry	Fixed, heavy, not suitable for mobile use

Ringg Outdoor Club

Outdoor Cooking Kits for Breakfast, Burgers, Steak, Seafood, Vegetables & More

Designed for versatile outdoor cooking, Ringg Outdoor propane flat-top kits are ideal for breakfast, burgers, bacon, eggs, pancakes, fried rice, fajitas, vegetables, seafood, tortillas and more.



Collaborations with famous chefs and special events



Backyard Workshop



Paella event at the SPOGA+GAFA 2024 trade show



Cooking Event in Cappadocia

Experience
Videos



CHEF SERIES

COMPACT KIT

The Chef Series Compact Kit is designed for smaller get-togethers. Serving up to 12 people with ease, this kit is compact yet effective. The 18-inch enameled steel pan and 12-inch dual gas burner ensure quick and even cooking. Its easy portability makes it perfect for using in your backyard or for camping.



12 Servings



30.709 BTU



2 Burners

COST: \$74.03

MSRP: \$148

ITEM CODE: CS001

Silicone Handle Holders

18 Inch Enameled Steel Pan

12 Inch Dual Gas Burner

Windshield

Robust Stand



CHEF SERIES

CLASSIC KIT

The Chef Series Classic Kit - our signature collection, crafted for those who embrace the chef within. Bringing the authentic taste to your backyard with ease. Engineered to serve up to 16 people, this kit includes all essential components for both corporate events and social gatherings.



16 Servings



38.898 BTU



2 Burners

COST: \$84

MSRP: \$170

ITEM CODE: CS002

Silicone Handle Holders

22 Inch Enameled Steel Pan

16 Inch Dual Gas Burner

Windshield

Robust Stand



CHEF SERIES

PRO KIT

The Chef Series Pro Kit is designed for large events and gatherings, offering a professional edge for those who love to entertain. Serving up to 20 people. With its advanced burners and large cooking surface, this kit is engineered to produce exceptional paellas ensuring a professional experience for all attendees.



20 Servings



49.134 BTU



2 Burners

COST: \$95.03

MSRP: \$190

ITEM CODE: CS003

Silicone Handle Holders

24 Inch Enameled Steel Pan

20 Inch Dual Gas Burner

Windshield

Robust Stand

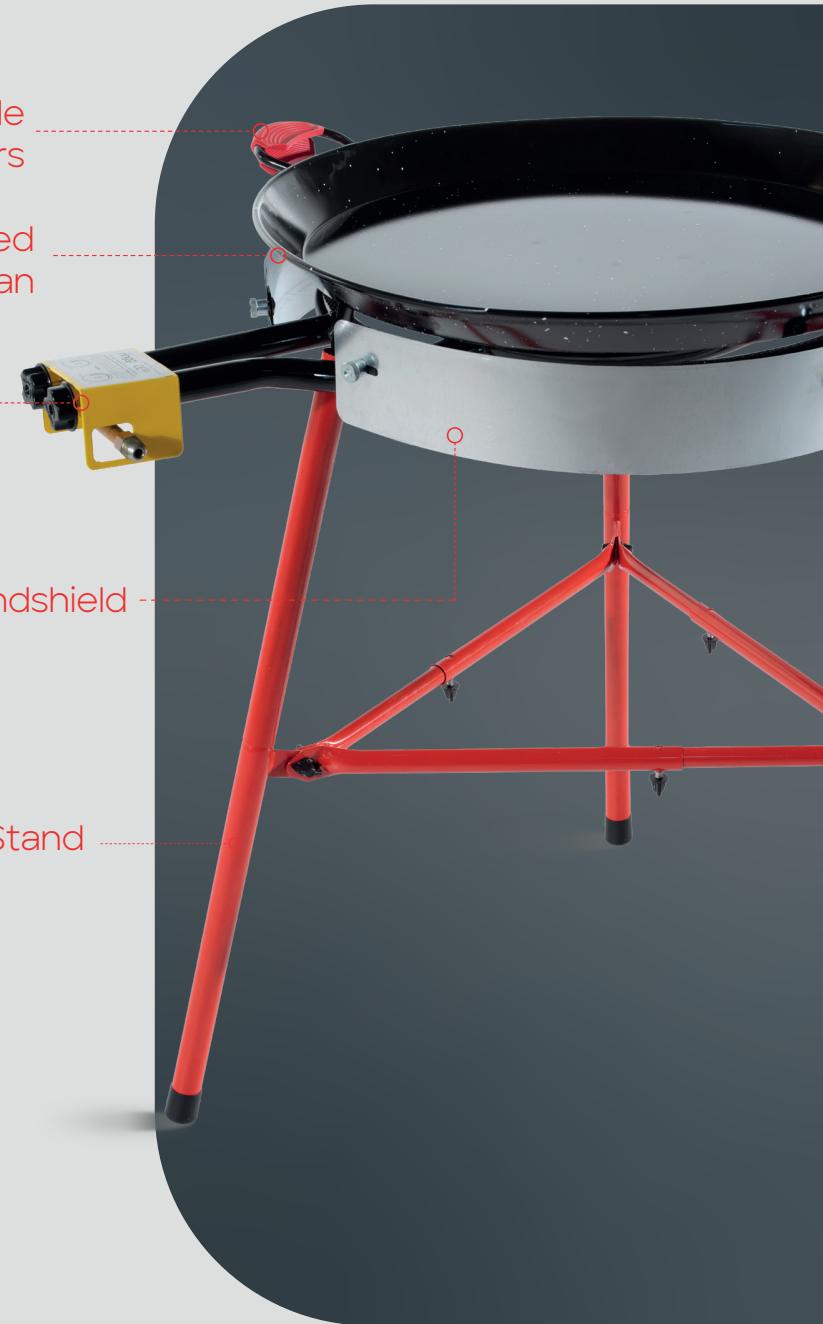

BLACK SERIES

CLASSIC KIT

The Black Series Classic Kit includes a 16-inch burner, a 20-inch enameled steel pan, and a foldable Base stand for easy transport and storage. Its sleek design and sturdy build make it ideal for outdoor cooking, from casual gatherings to special celebrations, offering lasting performance and effortless setup wherever you take it.



14 Servings



38,898 BTU



2 Burners

COST: \$89.51

MSRP: \$179

ITEM CODE: BS001



BLACK SERIES

PRO KIT

The Black Series Pro Kit - our most durable and refined collection - is built to perform in extreme conditions while maintaining a sleek, modern look. Featuring our sturdiest Frame foldable stand, it delivers both strength and convenience. This kit is designed for demanding outdoor environments, from camping adventures to high-capacity events.



20 Servings



49.134 BTU



2 Burners

COST: \$109.52

MSRP: \$219

ITEM CODE: BS002



FLAME SERIES

CLASSIC KIT

The Flame Series Classic Kit is designed to serve up to 16 people, making it ideal for family gatherings and friendly get-togethers. The 16-inch dual gas burner and 5-inch tabletop stand provide the power and stability you need to cook delicious meals.



16 Servings



38,898 BTU



2 Burners

16 Inch Dual Gas Burner

Butane/Propane Gas



COST: \$53.03

MSRP: \$110

ITEM CODE: FS001

FLAME SERIES

PRO KIT

The Flame Series Pro Kit is crafted for larger gatherings, this kit serves up to 24 people. The 24-inch triple gas burner and sturdy 5-inch tabletop stand offer exceptional performance and convenience, allowing you to prepare food professionally. Designed for big family reunions, community events or any special occasion, this kit is all about bringing people together over great food.



24 Servings



71,645 BTU



3 Burners

24 Inch Dual
Gas Burner

Butane/Propane
Gas



COST: \$70.04

MSRP: \$140

ITEM CODE: FS002

ENAMELED STEEL PAN

The enameled steel pan, with its even heat distribution, ensures that every ingredient is cooked to perfection, a balance of textures and tastes. Our pans are crafted with care and dedication, designed to help you make every meal a statement.



15 Inch Enameled Pan



8 Servings

COST: \$19.6

MSRP: \$37

ITEM CODE: PP15

18 Inch Enameled Pan



12 Servings

COST: \$24.1

MSRP: \$45

ITEM CODE: PP18

20 Inch Enameled Pan



14 Servings

COST: \$25.1

MSRP: \$50

ITEM CODE: PP20

22 Inch Enameled Pan



16 Servings

COST: \$27.6

MSRP: \$60



ITEM CODE: PP22

Burner Kit

Package Contents

-  Enameled Steel Pan
-  Dual Gas Burner
-  Robust Stand
-  Windshield
-  Regulator and Gas Hose
-  Silicone Handle Holders
-  Outdoor Cover

Features

-  Portable & Durable
-  Easy setup, fully equipped, practical experience.
-  Complete Kit. Ready to Use.
All essential components are included in one kit, allowing you to begin cooking immediately.

*Propane tank not included.



Everything you need,
all in one package.
*Experience-driven
designs from Ringg Outdoor.*



Trusted by Leading Retailers

Major retail chains such as Metro, Makro, and Bauhaus across Spain, France, and Sweden rely on Ringg Outdoor products, reflecting our consistent quality and strong market presence.



Our Journey So Far

135th Canton Fair Phase 1 - 2024

📍 Guangzhou - The People's Republic Of China

Spoga + Gafa 2023 & 2024 & 2025 & 2026

📍 Cologne, Germany

Ambiente 2023 & 2024 & 2025 & 2026

📍 Frankfurt, Main

The Inspired Home Show 2024 & 2025 & 2026

📍 McCormick Chicago

ASD Market Week 2025 & 2026

📍 Las Vegas Convention Center

Where will you cook?

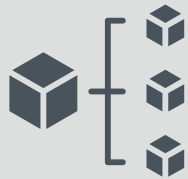

Become
a distributor



Contact us

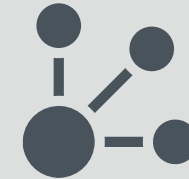

Explore private
label options

The flame is yours



KAYMET GROUP

U.S. Branch

11417 Irving Park Rd,
Franklin Park, IL 60131
+1 (630) 489 6991

Europe Corporate Headquarters

Anbar Dist. Nayman St. No: 26
Melikgazi/KAYSERI
+90 (352) 327 07 07

info@ringgoutdoor.com

www.ringgoutdoor.com